

SCREW AIR COMPRESSOR CONTROLLER

MAM-KY16S (B)

(MONITOR MAM-200)

USER

MANUAL

Shenzhen Plot Electronic Co., Ltd

Address: 4th Floor,5th Building,Highstar Industry Estate,Gangtou ,Bantian,
Shenzhen City, China

Telephone: (0755) 83172098 83172822 Postal code: 518129

Fax: (0755) 83172966 E-mail: plt@pltsz.com

Web site: www.pltsz.com

VOTE OF THANKS

Thank you for your trustworthy and select of PLOT air compressor controller KY16S!

Shenzhen Plot Electronic Co., Ltd specializes on the manufacture and R&D of air compressor controller. We are devoted to win customer trust through our high quality products and service.

We try our best to ensure the completeness and correctness of the manual, but PLOT Company shall reserve the rights for continuous research and improvement on its products and assume no obligation for the modification and improvement on the previously delivered products. The design of products is subject to the change without notice.

Please feel free to contact our after-sale service center if you encounter any problem with our product.

You are always welcome to make suggestions and advices!

NOTICE



Please read all the operation manual before operating the set and keep this manual for further reference.



Installation of MAM—KY** compressor controller can be performed only by professional technicians.



Installation position shall be considered carefully in order to ensure good ventilation and reduce electromagnetic interference.



Wiring shall be performed respectively according to regulations for heavy and weak current to reduce electromagnetic interference.



RC snubber must be connected to the two terminals of coil (such as AC contactor ,valve, etc),which are controlled by relay output.



Port connection shall be inspected carefully before power on.



Correct ground connection (the third ground)can help increase product capacity of resisting signal interference.



Set rated current of motor: the max current of motor/1.2.

Features:

- Chinese / English display
- On/off ,process control of motor
- Delay on/off ,process control of Drier
- Prevention for air compressor reversal
- Temperature measurement , control and protection
- Balance pressure through automatic load rate adjustment
- High integration ,high reliability ,high cost performance
- Far/Near Mode
- Block/Alone Mode
- RS-485communication function

Content

1、 Basic Operation	- 4 -
1.1、 Button explanation	- 4 -
1.2、 Status Display and Operations	- 5 -
1.3、 Calendar	- 6 -
1.4、 Customer Parameter	- 6 -
1.5、 Factory Parameter	- 9 -
1.6、 Operating Authorization and Password	- 10 -
2、 Controller Function and Technical Parameter	- 10 -
3、 Model and Specification	- 11 -
3.1、 Main Controller Model Description	- 11 -
3.2、 Monitor Description	- 11 -
3.3、 Power consumption Table for Corresponding Motor	- 12 -
4、 Installation	- 12 -
4.1、 Mechanical Installation	- 12 -
4.2、 Electrical Wiring Installation	- 14 -
5、 Alarm Function	- 15 -
5.1、 Monitor text	- 15 -
5.2、 Controller indicator	- 16 -
6、 Controller Protection	- 16 -
6.1、 Motor protection	- 16 -
6.2、 Protection of Air Temperature High	- 16 -
6.3、 Protection of Air Compressor reversal	- 16 -
6.4、 Protection of Air Pressure High	- 16 -
6.5、 Protection of Sensor Failure	- 17 -
7、 Troubleshooting	- 17 -
7.1、 This Fault Review	- 17 -
7.2、 Common Failures and Causes:	- 18 -
8、 Electronic Diagram	19

1、 Basic Operation

1.1、 Button explanation

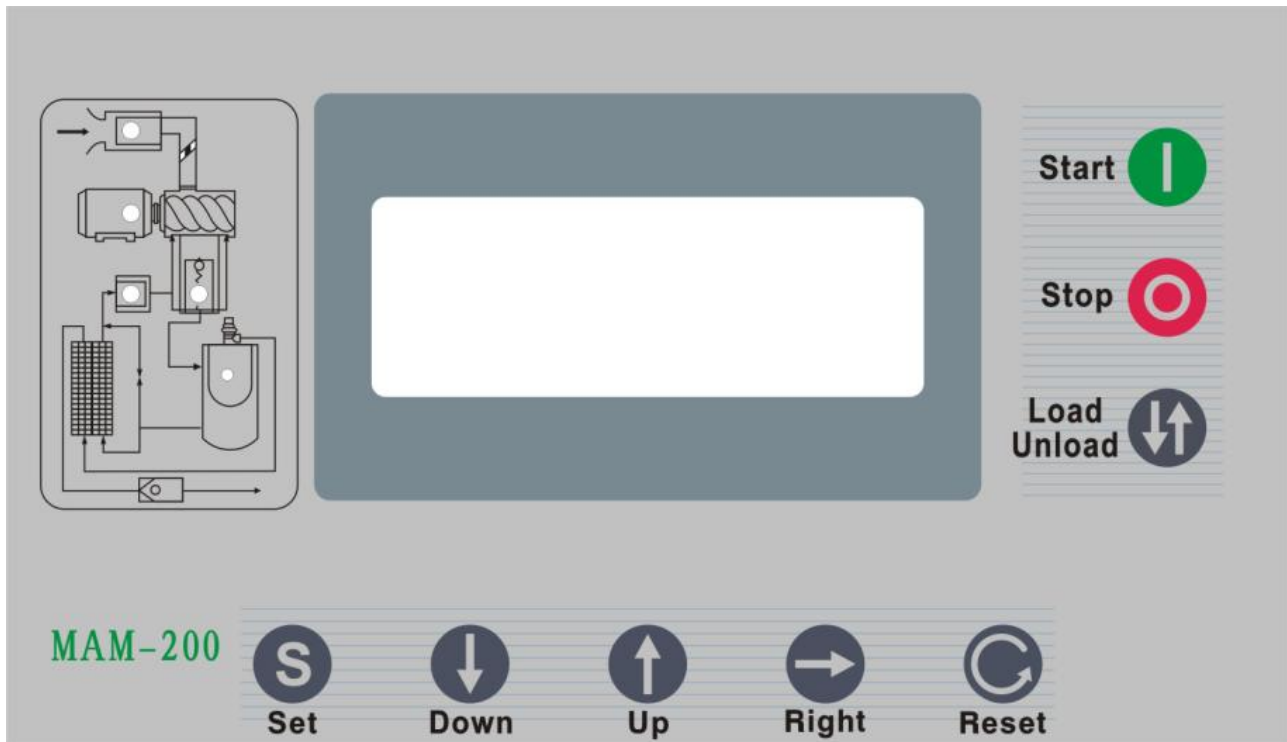

Pic 1

 — Start Button:

- When compressor is at stop status, press this button to start the compressor.
- When compressor is set as main (No. 1) in block mode ,press this button to start the compressor and activate block mode function at the same time.

 — Stop Button:

- When the compressor is at running status, press this button to stop the compressor;
- When compressor is set as main (No.1) in block mode ,press this button to stop compressor and block mode as well;

 — Loading / unloading Button:

- When the compressor is at running status ,press this button to load or unload

 — Set Button:

- When the compressor is at setting mode, press this button after modification to confirm and save the modified data.
- Press this button after input password to verify the password.

 — Move down button / Decreasing button:

- When viewing the menu, press this button to move downward the cursor.
- When modifying data, press this button to decrease the data at current position.



Move up button/Increasing button:

- when viewing the menu, press this button to move upward the cursor ;
- When modifying data, press this button to increase the data at current position .



Shift button /Enter button:

- When modifying data, press this button to move to the next data bit;
- When select menu, press this button to switch to sub menu .If no submenu available, the controller will shift to data setting mode.



Return button / Reset button:

- When modifying data, press this button to exist data setting mode
- When viewing the menu, press this button to return to previous menu;
- When the controller is at failure stop status, long press this button to reset.

1.2、 Status Display and Operations

The display screen will show as below after powered on:

```

WELCOME USING
SCREW COMPRESSOR
  
```

After 5 seconds, the menu will switch as below:

```

AIR T: 20 °C    FR T: 97 °C
AIR P: 0.60MPa  BR T: 95 °C
STATE: NORMAL STOP
ADD                                001
  
```

Press “↓” to enter into Selection Menu:

```

RUN PARAMETER
CALENDAR
CUSTOMER PARAMETER
FACTORY PARAMETER
  
```

Check RUN PARAMETER

Press“↓” or“↑”to move the cursor to “RUN PARAMETER”, then press“→”to switch to secondary menu:

```

MOTORS CURRENT
COIL、 ROTORS T
TOTAL RUN TIME
THIS RUN TIME
  
```

Press “→”to switch to the below menu

CUR (A):	R	S	T
HOST:	00.0	00.0	00.0
FAN:	4.1	4.1	4.1

No black cursor appears in the last menu. Press“ ↵ ”to return to the previous menu or the main menu. If no operation at the current menu for a few seconds, controller will automatically return to the main menu

Use Move down button“↓”、 Move up button“↑”、 Enter button“→”and Return button“ ↵ ”to check COIL 、 ROTORS T、 TOTAL RUN TIME 、 THIS RUN TIME、 MAINTENANCE PARAMETER、 HISTORY FAULT、 PRODUCTION DATE、 NUM、 THIS FAULT and return to the previous menu.

1.3、 Calendar

Check and set time for controller

DATE AND TIME
2004 - 2 - 22
W 0
12 : 46 : 59

1. 4、 Customer Parameter

1) 、 Customer Parameter View and Modification:

——Customer Parameter and factory parameter is not allowed to modify in running and stop delay status——

When modify customer parameter, please refer to run parameter modification method. The modification process of LOADING P is showing as an example below:

Press “↓”or “↑” to move the cursor to “Customer Parameter”, press “→”to switch to the following menu

SET P、 T
SET TIME
OPERATION MODE
BLOCKING MODE

Then, press “→” to switch to the following menu:

LOADING P: 00.65MPa
UNLOADING P: 00.80MPa
FAN START T: 0080℃
FAN STOP T: 0070℃

User can check the CUSTOMER PARAMETER in this menu or press“→”to switch to the following menu which requires an enter password.

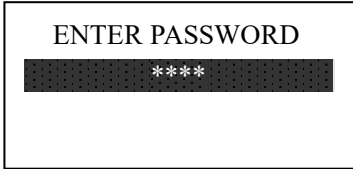

Note : Customer password can be set in CUSTOMER PARAMETER, and FACTORY PARAMETER is fixed as _____

In this menu, the first data bit of password started blinking , press“↓” or“↑” to modify the first bit of password, Press“→” move the cursor to the next data bit, modify the second data of password. In accordance with the above , modify the third and fourth data of password in sequence, press “S” to confirm the input data and the menu will switch to the following menu after verification:

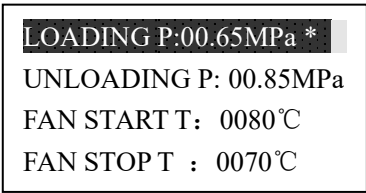

The upper right corner with “*” indicate the system verification of the password

In the menu above , press“→” , the first data of LOADING P starts to blink, user can press “↑” or “↓”to modify the present data in accordance with the above method .Press “→”to move to next data bit and modify the target data in sequence. When finished, press “S” to confirm and save the data. Other CUSTOMER PARAMETER share the similar way for modification.

2) Customer Parameter Table and Function

First menu	Second menu	Preset Data	Function
SET P、T	LOADING P	0.65 MPa	1,In AUTO LOADING status , compressor will load if pressure is below this set data 2,In STANDBY mode, compressor will start if the pressure is below this set data
	UNLOADING P	0.80MPa	1.Compressor will unload automatically if air pressure is above this set data This data should be set above LOADING P ,also should be set below ULD LIM P
	FAN START T	80°C	Fan will start if AIR T is above this set data
	FAN STOP T	70°C	Fan will stop if AIR T is below this set data
SET TIME	HOST START TIME	0008S	Set the HOST START TIME, record time when HOST is activated, controller will not start overload protection during this time to avoid stopping the motor by impulse starting current
	FAN START TIME	0006S	Set the FAN START TIME, record time when fan is activated, controller will not start overload protection during this time to avoid stopping the fan by impulse starting current
	OTHER	0001S	Fixed as 1 S
	LOAD DELAY TIME	0002S	Unloading in this set time after enter delta running

	EMPTY DELAY TIME	0020M	When unloading continuously, compressor will automatically stop and enter to standby status if over this set time
	STOP DELAY TIME	0010S	For NORMAL STOP operation, compressor will stop after it continuously unloading over this set time
	START DELAY TIME	0100S	Machine can be restarted only over this set time at any case(after NORMAL STOP, STANDBY or FAILURE STOP)
	OTHER	0000S	Standby
	DRAIN OPEN TIME	0002S	Continuously drain time in auto mode
	DRAIN CLOSE TIME	0010M	Interval drain time in auto mode
OPERATION MODE	ON/OFF MODE	NEAR/FAR	1.When set as NEAR ,only the button on the controller can turn on and turn off the machine. 2.When set as REMOTE mode, both the button on the controller and the remote control button can turn on and off the machine;
	LOAD MODE	AUTO/MANU	1.When set as the MANU : only when the pressure is above UNLOAD P, compressor will unload automatically .For any other case, the Load/Unload function can only be executed by pressing load/unload key. 2.When set as AUTO ,the loading/ unloading function can be executed by the fluctuation of AIR P automatically
	COM MODE	PROHIBIT/COMPUTER/BLOCK	1. When set as PROHIBIT, the communication function is invalid. 2.When set as COMP, compressor can communicate with computer or DCS as slave according to MODBUS-RTU. 3.When set as BLOCK, compressor can work in net
	COM ADD	0001	Set the communication ADD in block mode or when communicate with monitoring center . This ADD is unique for every controller in net
BLOCKING MODE	BLOCK STATE	MAIN/SLAVE	1.When service as main in BLOCK. Main controls slave, the COM ADD should be set as No.1 2.When service as slave in BLOCK, slave is controlled by main
	BLOCK ON/OFF	ORDER/ALONE	Standby
	TURN TIME	9999H	When main pressure is between BLOCK LOAD P and BLOCK UNLOAD P, motor determine slave work alternatively over this set time .
	BLOCK NUMBER	0016	Number of air compressors in block net
	BLOCK LOAD P	2.00MPa	In BLOCK mode, one compressor will start or load when pressure is below this set data
	BLOCK UNLOAD P	2.00MPa	In BLOCK mode, one compressor will stop or unload when pressure is above this set data
	BLOCK DELAY	0000S	In BLOCK mode, when main sends two commands continuously, second command signal delays for this set data,
CLR LIFE TIME	OIL RESET	0000H	Record oil filter total run time. If changing new oil filter, the data should be reset by manual operation.

	O/A RESET	0000H	Record O/A separator total run time. If changing new O/A separator, the data should be reset by manual operation
	AIR RESET	0000H	Record air filter total run time. If changing new air filter, the data should be reset by manual operation
	LUB RESET	0000H	Record lubricating oil total run time. If changing new lubricating oil, the data should be reset by manual operation
	GREASE RESET	0000H	Record grease total run time. If changing new grease, the data should be reset by manual operation
MAX LIFE TIME	OIL	9999H	1,Alarm prompt when total run time of oil filter is over the data set. 2,Set this data to "0" to invalidate the oil filter alarm function
	O/A	9999H	1,Alarm prompt when total run time of O/A separator is over the set data. 2,Set this data to "0" to invalidate the O/A separator alarm function
	AIR	9999H	1,Alarm prompt when total run time of air filter is over the data set. 2,Set this data to "0" to invalidate the alarm function of air filter
	LUBE	9999H	1,Alarm prompt when total run time of lubricating oil is over the parameter set. 2Set this data to "0" to invalidate the alarm of lube.
	GREASE	9999H	1,Alarm prompt when total run time of grease is over the parameter set. 2Set this data to "0" to invalidate the alarm of grease.
LANGUAGE SEL	CHINESE/ ENGLISH	CHINESE	Chinese display when set to CN English display when set to EN
NEW UNSER PASSWORD		****	User could modify the user password by old user password or factory password

1.5、Factory Parameter

The view and modification of factory parameter requires a factory password, The modification step is same as customer parameter modification. Main function is as below:

PARAMETER	Initial Data	Function
HOST RATED CUR	Maximum host overload data/1.2	When the current of host is more than 1.2 times and less than 4 times of the set data , the unit will shut down according to overload feature.
FAN RATED CUR	Maximum fan overload data/1.2	When the current of fan is more than 1.2 times and less than 4 times of the set data , the unit will shut down according to overload feature.
PRE-ALARM T	105℃	Alarm prompt when actual AIR T is over the set data
AIR STOP T	110℃	Alarm and stop when actual AIR T is over the set data
STOP P	1.00Mpa	Alarm and stop when actual AIR P is above this set data
UNLOAD LIM P	0.80Mpa	The UNLOAD P in CUSTOMER PARA must be set no higher than this set data.
CLR LOAD TIME	000000H	Modify the LOAD TIME
CLR TOTAL TIME	000000H	Modify the TOTAL RUN TIME

CLR FAULT RECORD	0000	Input the password “8888” and press “set “button to clear all the history failure record.
UNBALANCE SCOPE	0006	MAX-MIN \geq SET*MIN/10 ,respond time is 5s If the set data \geq 15, the unbalance protection will be invalid.
LACK PHASE STOP	000.5S	If LACK PHASE protection \geq 20 seconds, LACK PHASE protection is invalid
ROTOR STOP T	0160°C	Alarm and stop when the rotor temperature is higher than this set data
PROD TIME	****_**_**	Production date
PROD NUM	*****	Product serial No.
COIL STOP T	0160°C	Alarm and stop when the coil temperature is higher than this set data
WARM START T	0060°C	In stop mode, when coil 1 temperature is lower this set data, heater relay will close
WARM STOP T	0080°C	In stop mode, when coil 1 temperature is higher this set data, heater relay will open
COM SET PARA	ENABLE/DISABLE	Set controller parameter through DCS center

1.6、 Operating Authorization and Password

Controller provides multiple passwords and access management. According to different levels of passwords, controller provides different levels of operating authorization.Details as following:

1.6.1 CUSTOMER PASSWORD: factory set _____

Permissions:Allows to modify all CUSTOMER PRAMETER.

1.6.2 FACTORY PASSWORD: fixed: _____

Permissions: Allows users to modify all CUSTOMER PARA and FACTORY PARA.

2、 Controller Function and Technical Parameter

- 1、 Digital input & output: 9 points of Digital input ;10 points of digital relay output;
- 2、 Analog input: 6 points of Pt100 temperature input, 1 point of 4~20mA pressure signal input, 11 group of three phases current inputs(CT provided) ;
- 3、 Input voltage of phases:380V;
- 4、 Compressor working power supply: 220V、 50Hz、 20VA;
- 5、 Measurement :
 - ①、 AIR T: —20~178°C; Accuracy: \pm 1°C.
 - ②、 Run time: 0~999999H.
 - ③、 Current: 0~999.9A.
 - ④、 Pressure: 0~1.60MPa. Accuracy: 0.01Mpa.
- 6、 Phase sequence protection: When compressor is at stop mode and detects wrong phase, respond time \leq 2s
- 7、 Motor protection : This controller has five basic protection function for motor and fan.
 - ①、 Block protection: After start, When operation current is equal to 4 ~8 times the set current ,respond time \leq 0.2s;
 - ②、 short circuit protection: When operation current is equal to 8 times the set current, respond time \leq 0.2s;
 - ③、 Phase lack protection: When any phase lack ,the respond time equals to set time;
 - ④、 Unbalance protection: when MAX-MIN \geq SET*MIN/10 ,respond time is 5s;

⑤、Protection features of overload (time unit: second), please see following table (table 2.7.1) , multiple = $I_{\text{actual}} / I_{\text{set}}$,motor operates with delay time according to overload multiples and operation time shown in following table (table 2.7.1) when motor working current is higher or equal to the set current from 1.2 times and 3.0 times .

$I_{\text{actual}}/I_{\text{set}}$	≥ 1.2	≥ 1.3	≥ 1.5	≥ 1.6	≥ 2.0	≥ 3.0
Time parameter						
Response time (S)	60	48	24	8	5	1

Table2.7.1curve table for protection of motor

- 8、 Temperature protection: when actual temperature measured is higher than temperature set; response time ≤ 2 s;
- 9、 Contact capacity of output relay: 250V,5A; Contact endurance :500000 times
- 10、 Current error is less than 1.0%.
- 11、 RS—485 communication

3、 Model and Specification

3.1、 Main Controller Model Description

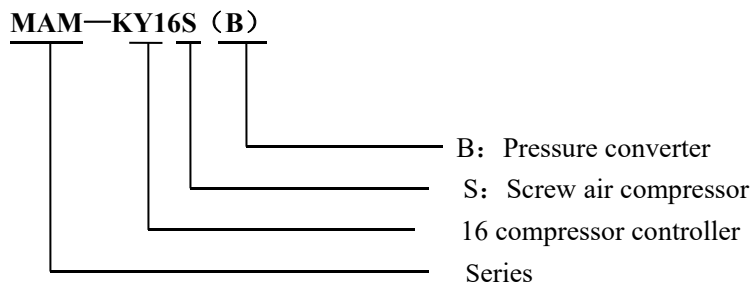

3.2、 Monitor Description

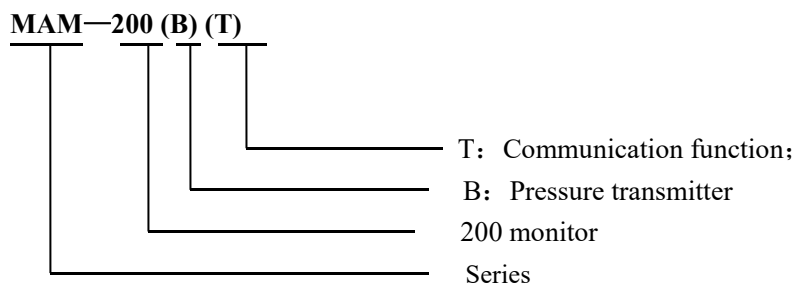

3.3、Power consumption Table for Corresponding Motor

Parameter Specification	Current range (A)	Corresponding main motor power (KW)	Remark	Description
KY16S (20)	8~20	Below 11		Fan has three levels of current, such as 0.2-2.5A, 1-5A and 4-10A, determined by current of motor
KY16S (40)	16~40	11-18.5		
KY16S (100)	100	22-45		
KY16S (200)	200	55-90		
KY16S (400)	400	110		
KY16S (600/5)	600/5	200-250	With CT	

4、Installation

4.1、Mechanical Installation

①、Current transformer installation

The CT shall be installed at a place where the current of motor cable can be measured, thus controller can be set according to instructions on motor nameplate, the detailed dimensions is shown as below:

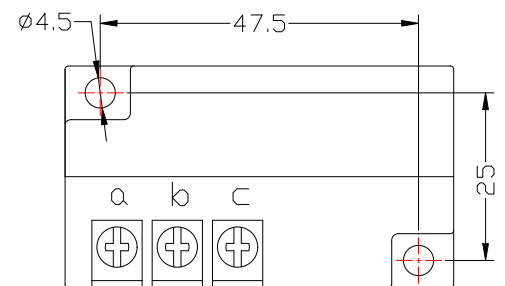
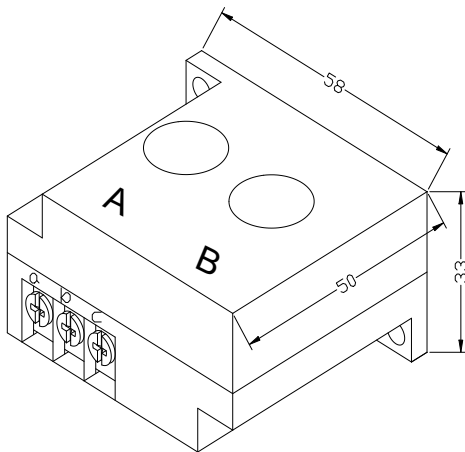

Pic 4.1.1、Structure dimensions CT2 (φ10through hole)

Pic4.1.2、Installation dimensions of CT2

②、Controller installation

A certain room should be left around controller for wiring. The specific dimension is shown as below:

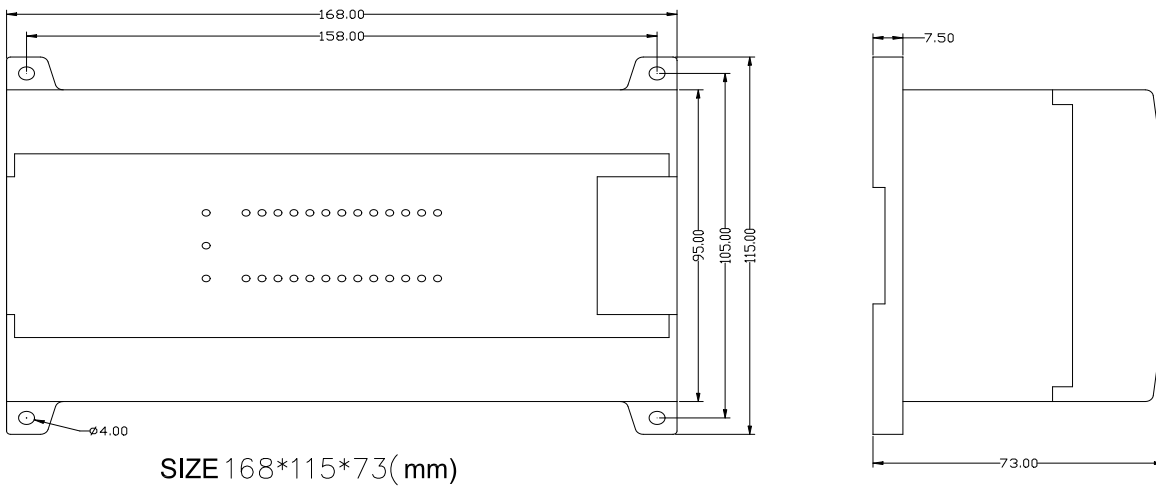

4.1.3、 Controller structure dimension

1、 Indicator (IN) :

The corresponding digital input terminal of 00、 01、 02、 03、 04、 05、 06、 07 is 26、 25、 24、 23、 22、 21、 20、 19、 18.

2、 Indicator (OUT)

The corresponding digital output terminal of 00、 01、 02、 03、 04、 05、 06、 07、 08、 09 is 39、 40、 41、 42、 43、 46、 47、 49、 50、 51.

3、 Power indicator: PWR indicator

4、 Run indicator: RUN indicator

5、 Error indicator: ERR indicator

③、 Panel function and installation

MAM 200 monitor in control cabinet.

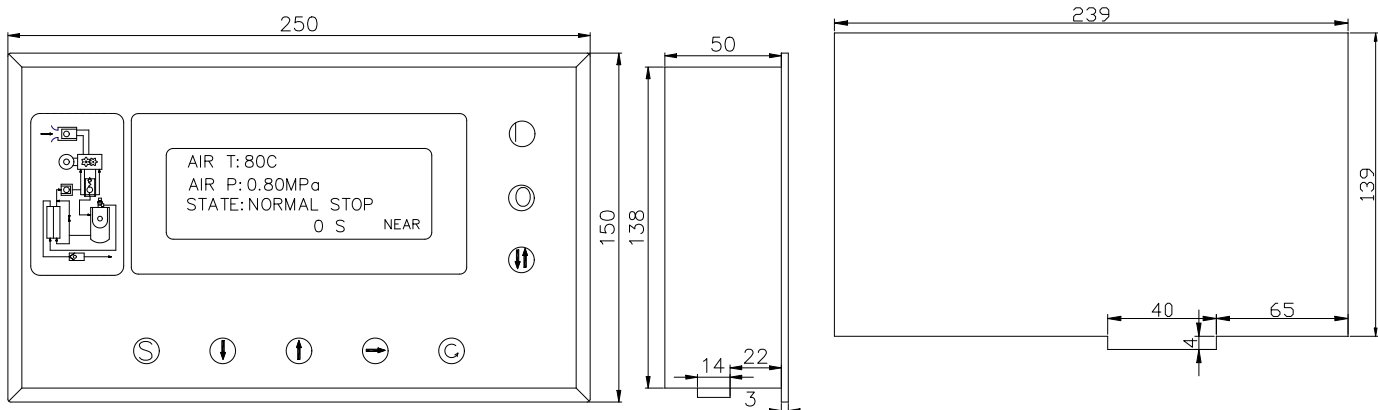

Pic4..1.4、 Panel and hole dimension

4.2、Electrical Wiring Installation

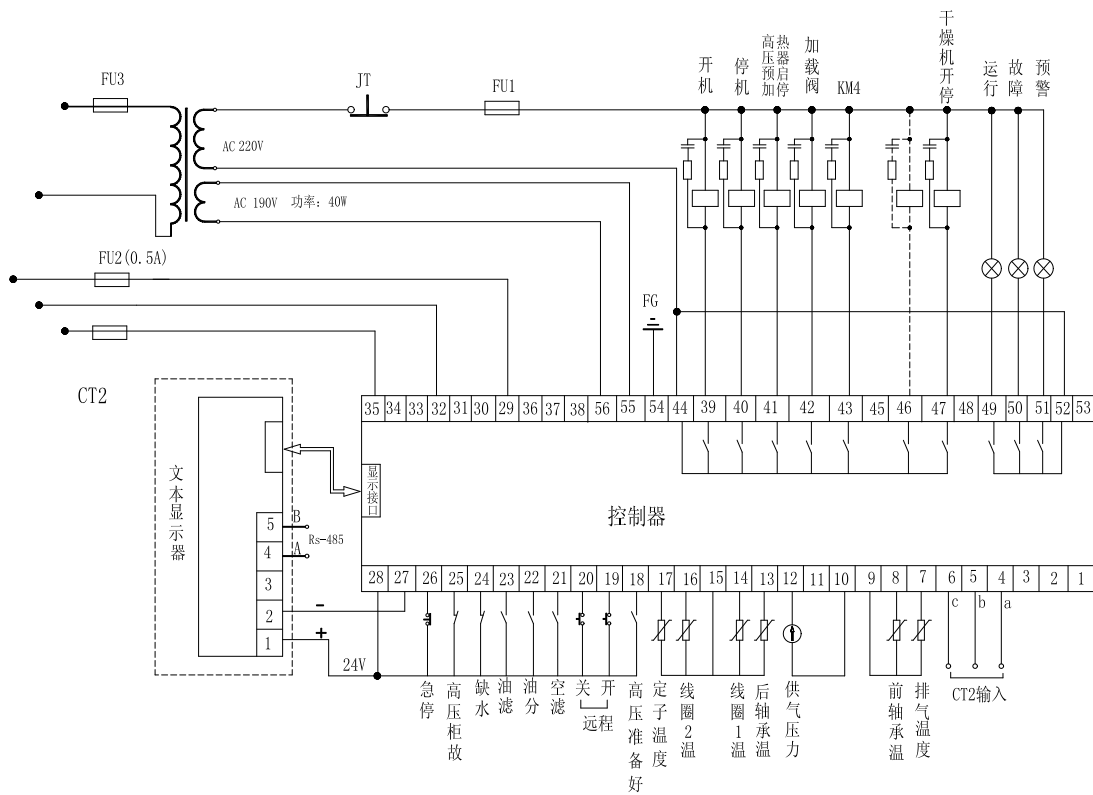

Pic4.2.1、Terminal arrangement diagram

Monitor connection cable:

There are six connection cable and a communication cable which are used for display connection ,RS-485 communication ,24V power supply. For detail , please refer to the silk print in monitor

Controller cable terminal:

Communication cable is used to connect monitor and controller.

1、 2、 3	N/A	4、 5、 6	Terminal for fan CT2 input	7、 9	Input terminal for AIR T
8、 9	Input terminal for front rotor temperature	10、 12	Input terminal for AIR P	11	N/A
13、 15	Input terminal for rear rotor temperature	14、 15	Input terminal for coil 1 temperature	15、 16	Input terminal for coil 2 temperature
17、 15	Input terminal for coil 3 temperature	18	High voltage ready	19	“Remote” on
20	“Remote” off	21	Differential pressure switch for air filter	22	Differential pressure switch for oil/air separator
23	Differential pressure switch for oil filter	24	Lack water	25	High voltage cabinet error
26	Emergency stop	27	24V output —	28	24V output +
29、 32、 35	Input terminal for phase sequence	30、 31	N/A	33、 34	N/A
36、 37、 38	N/A	39	Output signal, start high	40	Output signal, stop high

			voltage cabinet		voltage cabinet
41	High voltage pre-heater on/off	42	Control valve	43	Control fan
44	Common terminal for output control	45	N/A	46	Operation ready
47	Dryer	48	N/A	49	Run indicator
50	Alarm stop indicator	51	Alarm indicator	52	Common terminal for indicator
53	N/A	54	Terminal for ground connection	55、56	220V power supply

Note: 39 terminal: start high voltage cabinet. When turn on, it will close for 5 s and then open

40 terminal: stop high voltage cabinet. When turn off, it will close for 5 s and then open

*** Note : Electromagnetism coil shall be connected nearest with RC snubber during wiring**

5、 Alarm Function

5.1、 Monitor text

5.1.1、 Air Filter Alarm

- 1、 Use switching signal to detect Alarm

The monitor displays AIR FILTER BLOCK by checking air filter differential pressure switch.

- 2、 Set air filter max time

The monitor displays AIR LIFE END when the run time of the air filter exhausts.

5.1.2、 Oil Filter Alarm

- 1、 Use switching signal to detect Alarm

The monitor displays OIL FILTER BLOCK by checking oil filter differential pressure switch.

- 2、 Set oil filter max time

The monitor displays OIL LIFE END when the run time of the oil filter exhausts.

5.1.3、 O/A Alarm

- 1、 Use switching signal to detect Alarm

The monitor displays O/A BLOCK by checking O/A differential pressure switch.

- 2、 Set oil/air max time

The monitor displays O/A LIFE END when the run time of the O/A exhausts.

5.1.4、 Lubricating oil Alarm

The text displays LUBE LIFE END when run time of the lubricating oil exhausts.

5.1.5、 Grease Alarm

The text displays GREASE LIFE END when run time of the grease exhausts.

5.2、 Controller indicator

Indicator	Meaning and function	Indicator status
Power	Controller power on	PWR indicator on
Run	Controller run	RUN indicator on
Error	Failure and stop	ERR indicator blink
Digital input	Terminal 26~18 digital input	IN00~08corresponding indicator on. Indicator will not be illuminated if input has no function
Digital output	Terminal 39、 40、 41、 42、 43、 46、 47、 49、 50、 51digital output	OUT00~09 corresponding indicator on
Data storage	Data and time set	PWR blink once

6、 Controller Protection

6.1、 Motor protection

MAM — KY16Scompressor controller provide short circuit ,block, overload, lack phase, unbalance protection to motor.

Electronic failure	Failure display	Reason
Short circuit	Display “MOTOR /FAN OVER LOAD”	Short circuit or wrong current set
Current Block	Display “MOTOR /FAN BLOCK”	Overload, bearing wear and other mechanical failure
Overload	Display “MOTOR /FAN OVERLOAD”	Overload, bearing wear and other mechanical failure
Lack phase	Display “MOTOR /FAN *LACK PHASE”	Power supply, contactor and open phase of motor
Unbalance	Display “MOTOR /FAN UNBALANCE”	Poor contact of contactor, inside open-loop of motor

6.2、 Protection of Air Temperature High

When AIR T is above the AIR STOP T, the controller will send out the alarm to shut down the machine and This fault displays AIR T HIGHT .

6.3、 Protection of Air Compressor reversal

When compressor stops and three phases sequence is not in order, THIS FAULT displays PHASE REVERSAL, and the controller cannot start the motor. Change the position of any arbitrary two-phase power lines and check the rotation of motor.

6.4、 Protection of Air Pressure High

When the AIR P is above the STOP P, the controller will send out the alarm to shut down the machine and THIS FAULT displays AIR P HIGH .

6.5、 Protection of Sensor Failure

When pressure sensor or temperature sensor is disconnected, the controller will send out the alarm to shut down the machine and THIS FAULT displays **SENSOR FAULT.

7、 Troubleshooting

7.1、 This Fault Review

Failure stop caused by the external parts of controllers may be removed by checking THIS FAULT or HISTORY FAULT , method is shown as below:

Press“↓” or “↑”to move the cursor to RUN PARA menu, then press “→”the secondary menu would be prompted out:

MOTORS CURRENT

COIL、 ROTORS T

TOTAL RUN TIME

THIS RUN TIME

Press “↓”

MAINTENANCE PARAMETER

HISTORY FAULT

PRODUCTION DATE 、 NUM

THIS FAULT

Move cursor to THIS FAULT press“→”to switch to the following error menu:

STOP:T SENSOR FAULT

170°C

User can reset the error according to the following information

7.2、 Common Failures and Causes:

Failure	Reason	Solution
AIR T HIGH	Bad vent condition, Oil shortage etc.	Check the vent condition and lubricant amount etc.
AIR T SENSOR FAULT	Cable off or PT100 failure	Check the wiring and PT100
AIR P HIGH	Pressure too high or the pressure sensor failure	Check the pressure and the pressure sensor
AIR P SENSOR FAULT	Cable off, Sensor failure or sensor cable reversal	Check the wiring and pressure transmitter
LACK WATER	Water pressure switch failure	Check water pressure switch
LACK PHASE	Power lack phase or the contactor terminal failure	Check the power and contactors
OVERLOAD	Voltage too low, tubes block, bearing wear off or other mechanical failure or wrong set data etc.	Check the set data, voltage, bearings, tubes and other mechanical system.
UNBALANCE	Power unbalance, contactor failure or the internal open loop of the motor	Check the power, contactor and the motor
BLOCK	Voltage too low, tubes block, bearing wear off or other mechanical failure or wrong set data etc.	Check the set data, voltage, bearings, tubes and other mechanical system.
SHORT CIRCUIT	Wrong cable connection, wrong set data	Check the cable ,set the data
PHASE REVERSAL	Reversed phase sequence or open phase	Check the wiring
Overload and block during start	MAIN start time set to less than the STAR DELTA delay time	Reset the main start time to be longer than star delta delay + 2 seconds
Main Contactor shakes frequently	The emergency button loose, controller reset by interference	Check the wiring; if the coil of contactor connect with RC snubber or not

8、 Electronic Diagram

